



4426 Mt. Carmel Tobasco Rd.
Cincinnati, Ohio 45244

phone 513.528.7272 fax 513.528.1777

contact@alufab.cc www.alufab.cc

Toll Free 1.888.646.6097

06 | TSLOTS HARDWARE

This section includes everything you need to build panels and doors for guarding, bi-fold doors, sliding doors or enclosures. If you need something to complete a project and we don't have it, please contact us and we will source it for you.

TSLOTS Hardware

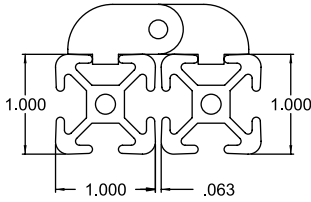

10 Series

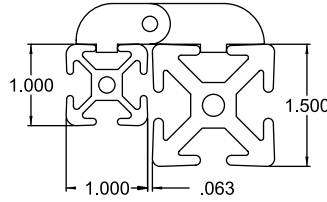

10 to 15 Series

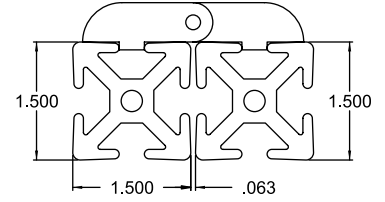

15 Series

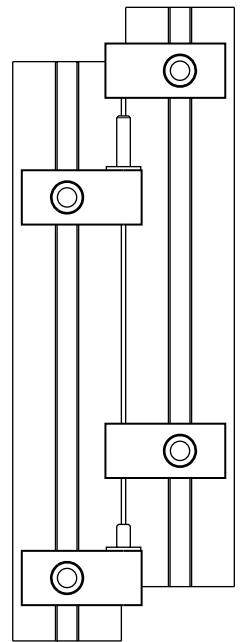
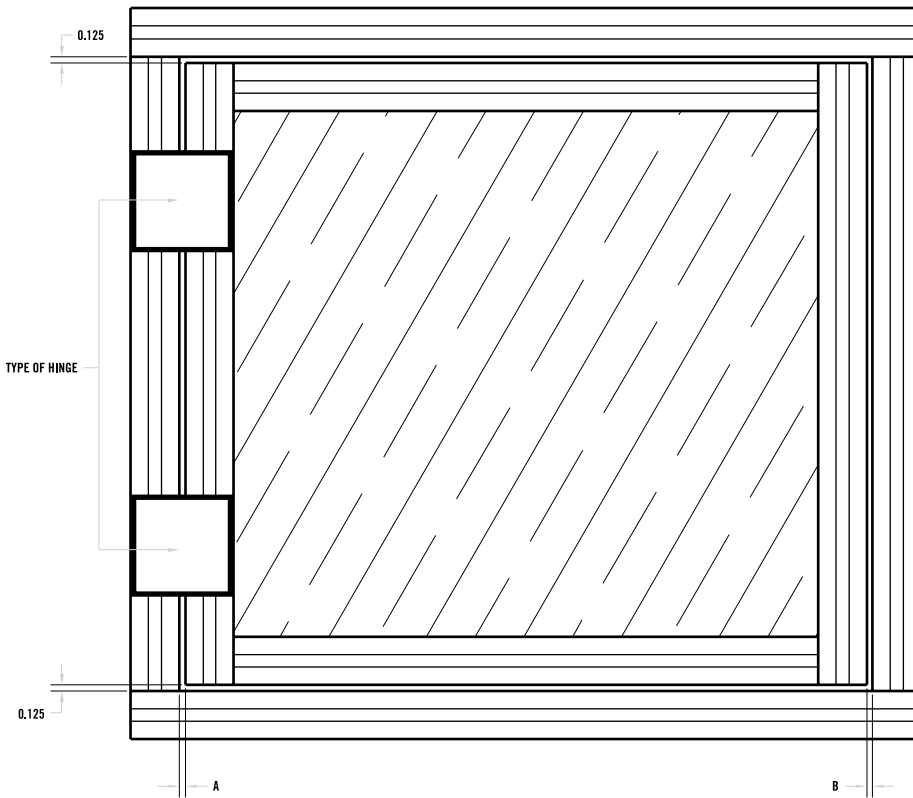

HINGE TYPE	DIMENSION A	DIMENSION B
15 S Lift Off Hinge Assembly	.063"	.187"
10 S Lift Off Hinge Assembly	.063"	.187"
10 S to 15 S Lift Off Hinge Assembly	.063"	.187"
15 S Aluminum Hinge (655082)	.125"	.125"
10 S Aluminum Hinge (655083)	.063"	.187"
10 S to 15 S Aluminum Hinge (655081)	.125"	.125"

* Note: For all doors, make the door .25" smaller in height and width than the door frame.

LIFT OFF HINGES



10 SERIES - LIFT OFF HINGES ^(25S)

ITEM #	DESCRIPTION
655070	10 S Right Hand Lift-Off Hinge w/ Long Pin
655071	10 S Left Hand Lift-Off Hinge w/ Long Pin
655072	10 S Right Hand Lift-Off Hinge w/ Short Pin
655073	10 S Left Hand Lift-Off Hinge w/ Short Pin
655074	10 S Lift-Off Hinge Section w/ Bushing
655075	10 S Lift-Off Hinge w/ Two Pins

15 SERIES - LIFT OFF HINGES ^(40S)

ITEM #	DESCRIPTION
655089	15 S Right Hand Lift-Off Hinge w/ Long Pin
655090	15 S Left Hand Lift-Off Hinge w/ Long Pin
655091	15 S Right Hand Lift-Off Hinge w/ Short Pin
655092	15 S Left Hand Lift-Off Hinge w/ Short Pin
655093	15 S Lift-Off Hinge w/ Bushing
655094	15 S Lift-Off Hinge w/ Two Pins

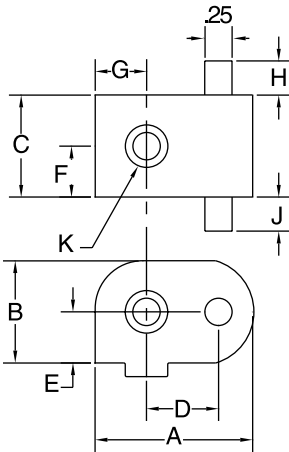

ITEM #	LBS	A	B	C	D	E	F	G	H	J	K
655070	0.06	1.156	0.500	0.750	0.529	0.250	0.375	0.377	N/A	N/A	10-32
655071	0.06	1.156	0.500	0.750	0.529	0.250	0.375	0.377	0.36	0.36	10-32
655072	0.055	1.156	0.500	0.750	0.529	0.250	0.375	0.377	N/A	N/A	10-32
655073	0.055	1.156	0.500	0.750	0.529	0.250	0.375	0.377	0.36	0.36	10-32
655074	0.065	1.156	0.500	0.750	0.529	0.250	0.375	0.377	N/A	N/A	10-32
655075	0.050	1.156	0.500	0.750	0.529	0.250	0.375	0.377	0.36	0.36	10-32
655089	0.085	1.156	0.500	0.750	0.780	0.250	0.375	0.625	N/A	0.750	1/4-20
655090	0.085	1.156	0.500	0.750	0.780	0.250	0.375	0.625	0.36	N/A	1/4-20
655091	0.080	1.156	0.500	0.750	0.780	0.250	0.375	0.625	N/A	0.36	1/4-20
655092	0.080	1.156	0.500	0.750	0.780	0.250	0.375	0.625	0.36	N/A	1/4-20
655093	0.090	1.156	0.500	0.750	0.780	0.250	0.375	0.625	N/A	N/A	1/4-20
655094	0.075	1.156	0.500	0.750	0.780	0.250	0.375	0.625	0.36	0.36	1/4-20

LIFT OFF HINGE ASSEMBLIES

	INDIVIDUAL PART NUMBER											
	655070	655071	655072	655073	655074	655075	655089	655090	655091	655092	655093	655094
655062	1		1		2							
655063		1		1	2							
655064		1	1	1								
655100							1		1		2	
655101								1		1	2	
655102									1	1	1	
	TRANSITION HINGES											
655097					2		1		1			
655098					2			1		1		
655099					1				1	1		

TSLOTS Hardware

PLASTIC HINGES ADJUSTABLE



ITEM #	DESCRIPTION
655077	15 S Black Adjustable Hinge
655078	10 S Black Adjustable Hinge

RECOMMENDED BOLT ASSEMBLY TO EXTRUSION

QTY	ITEM #
2	651150 (for 655077)
2	651204 (for 655078)

RECOMMENDED BOLT ASSEMBLY TO 1/4" PANEL

QTY	ITEM #
2	651195 (for 655077)
2	651206 (for 655078)

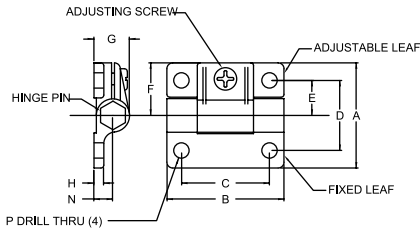

- Allows you to mount plastic panels and doors directly to TSLOTS
- Adjustable hinge allows you to increase or decrease pivot tension
- Adjustable Hinges are not suitable for hinging two TSLOTS extrusions together
- 10 and 15 Series sizes

ITEM #	A	B	C	D	E	F	G	H	N	P
655077	2.25	2.50	1.88	1.50	0.75	1.125	.770	.200	.410	.328
655078	1.44	1.69	1.25	1.00	0.50	0.72	.500	.230	.270	.197

PLASTIC HINGES



ITEM #	DESCRIPTION
655679	10S Heavy Duty Plastic Hinge
655680	15S Heavy Duty Plastic Hinge

RECOMMENDED BOLT ASSEMBLY

QTY	ITEM #
4	651185 (for 655679)
4	651204 & 651322 (for 655680)

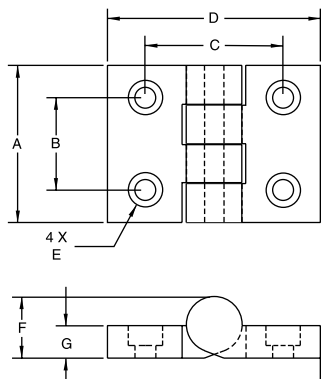

- Hinges TSLOTS Extrusions together
- 10 and 15 Series sizes

ITEM #	CAPACITY	A	B	C	D	E	F	G
655679	40 lbs	2.000	1.180	1.180	2.000	Drill & C'Sink For 1/4-20 FHCS	455	250
655680	75 lbs	2.000	1.180	2.000	2.750	Drill & C'Bore For 1/4-20 FHCS	775	400

ALUMINUM HINGE

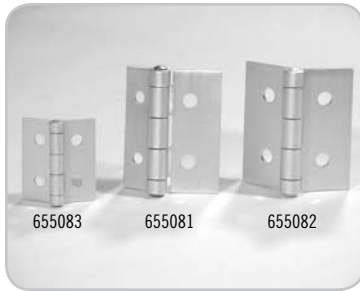

ITEM #	DESCRIPTION
655083	10 S Aluminum Hinge ^(25S)
655081	10 To 15 S Aluminum Transition Hinge
655082	15 S Aluminum Hinge ^(40S)

RECOMMENDED BOLT ASSEMBLY

QTY	ITEM #
4	(4) 651166 (For #655083)
4	(2) 651166 & (2) 655128 (For #655081)
4	(4) 651128 (For #655082)

- Mount heavier doors
 - 10 Series – 40 lb. capacity
 - 15 Series – 75 lb. capacity
- Hinges TSLOTS extrusions together
- Low profile mounts to T-Slot
- Clear anodize finish matches TSLOTS finish

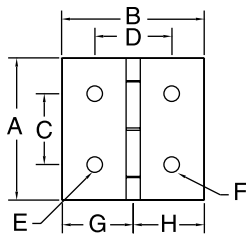

ITEM #	CAPACITY	A	B	C	D	E	F	G	H
655083	40 lbs	2.00	2.00	1.00	1.063	.257(4)	N/A	1.00	1.00
655081	75 lbs	3.00	2.50	1.50	1.375	.328(2)	.257(2)	1.50	1.00
655082	75 lbs	3.00	3.00	1.50	1.625	.328(4)	N/A	1.50	1.50

DOOR HANDLES



ITEM #	DESCRIPTION
655058	15 S Large Plastic Door Handle-Black ^(40S)
655059	15 S Medium Plastic Door Handle-Black ^(40S)
655060	10 S Small Plastic Door Handle-Black ^(25S)

RECOMMENDED BOLT ASSEMBLY

QTY	ITEM #
2	651234 (For Handle Item #655060)
2	651202 (For Handle Item #655059)
2	651202 (For Handle Item #655058)

- Mounts directly in T-Slot or machined panel
- Made of black polycarbonate
- 10 and 15 Series sizes

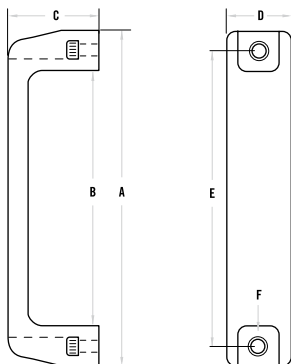

ITEM #	SERIES	A	B	C	D	E	F
655060	10 S	4.41	2.95	1.42	.830	3.678	1/4" SHCS (2)
655059	15 S	5.47	3.69	1.63	1.02	4.60	5/16" SHCS (2)
655058	15 S	7.75	6.02	2.00	1.10	7.05	5/16" SHCS (2)

TSLOTS Hardware

STEEL DOOR HANDLES



ITEM # DESCRIPTION
 655068 Steel Door Handle (25S) (40S)

- Mounts directly to panel or door
- Fasteners included – (2) 8-32 x 1/2" BHSCS
- 10 and 15 Series compatible

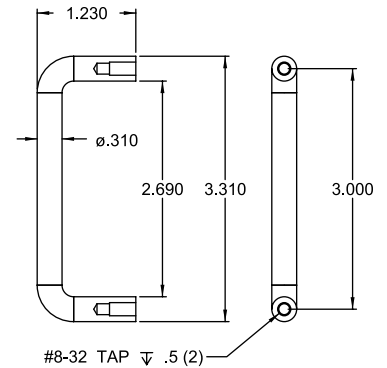

DELUXE DOOR HANDLE



ITEM # DESCRIPTION
 655053 Non-Locking Door Latch (25S) (40S)
 655061 Locking Door Latch w/Key (25S) (40S)

- Corrosion resistant chrome finish
- 15 Series size only
- Available in locking or non-locking handle
- Ideal for cabinets and guarding
- Fasteners Included – (2) 10-32 x 1 1/2" FHSCS
- Door Latch Milling Machining Service required – item number 660086, page 11:12.

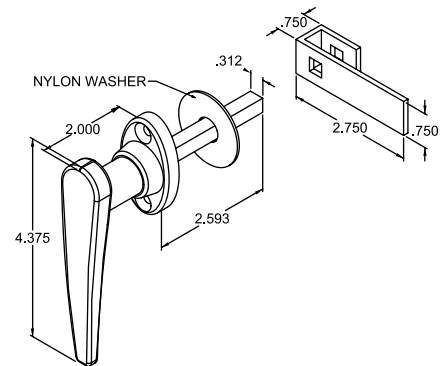

DEADBOLT LATCH



ITEM # DESCRIPTION
 655051 Deadbolt Latch w/ Top Latch 10 & 15 Series (25S) (40S)

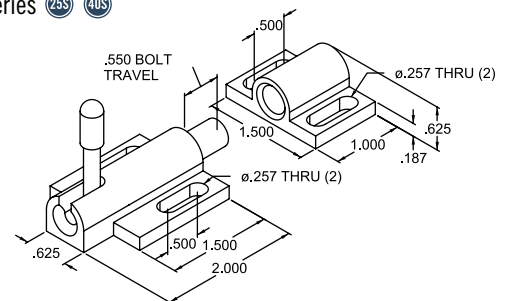

90° DEADBOLT LATCH



ITEM # DESCRIPTION
 655103 Deadbolt Latch With Side Latch  

- Positive, spring loaded deadbolt
- Ideal for enclosure doors
- 10 and 15 Series compatible
- Fasteners included – 651022, 651075
- Stainless Steel bolt, spring and handle
- Clear anodized aluminum body

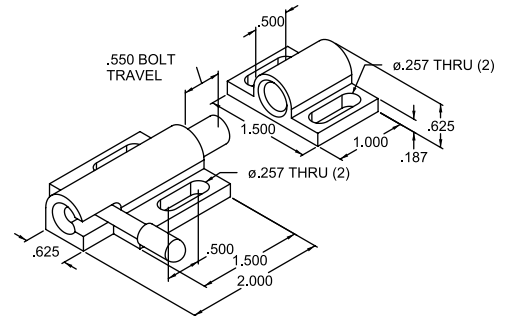

GRABBER™ DOOR CATCH



ITEM # DESCRIPTION
 655067 3 Lbs Pull Force Grabber Door Catch And Keeper
 655085 5 Lbs Pull Force Grabber Door Catch And Keeper
 655118 10 Lbs Pull Force Grabber Door Catch And Keeper

- Mounts inside your enclosure
- Push to close, pull to open
- Spring loaded over center action
- 3 pull-up forces to choose from
- Corrosion resistant black ABS
- 10 and 15 Series compatible
- Mounts to TSLOTS using Mounting Plates seen below.
- Fasteners included – (4) 6-32 BHSCS for mounting plates

Grabber™ Door Catch is a registered trademark of Southco, Inc.

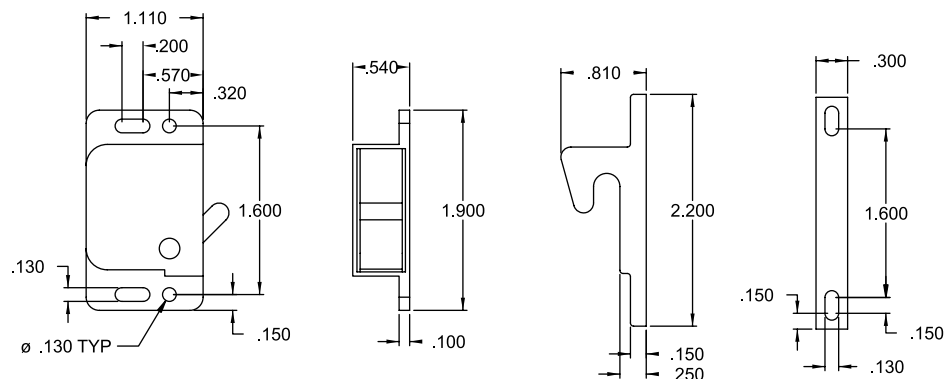

TSLOTS Hardware

GRABBER™ DOOR CATCH MOUNTING PLATES



ITEM #	DESCRIPTION
651117	10 & 15 S Grabber Door Catch Mounting Plate

RECOMMENDED FASTENERS

ITEM #	SERIES	DESCRIPTION
651155	10 S	Drop In T-Nut Kit
651156	10 S	Drop In T-Nut Kit
651224	15 S	Economy T-Nut Kit
651130	15 S	Economy T-Nut Kit

- Mounts Grabber™ Door Catch to TSLOTS
- Made from 1/4" clear anodized aluminum
- 10 and 15 Series Compatible

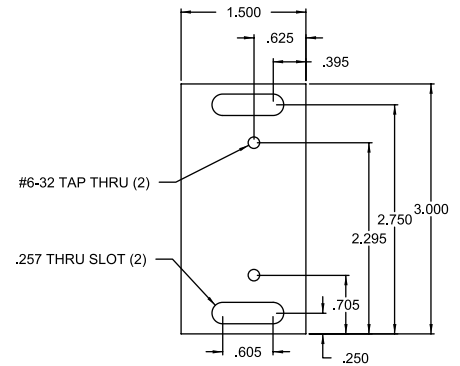

MAGNETIC DOOR CATCH



ITEM #	DESCRIPTION
655087	Magnetic Door Catch

- Ideal for latching panels in place
- 10 and 15 Series compatible
- Use with all TSLOTS extrusions
- Fasteners included
- To mount to extrusion, use either Magnetic Door Catch Bracket or Door Catch Mounting Plate on page 06:11 - for 0° or 90° connection.

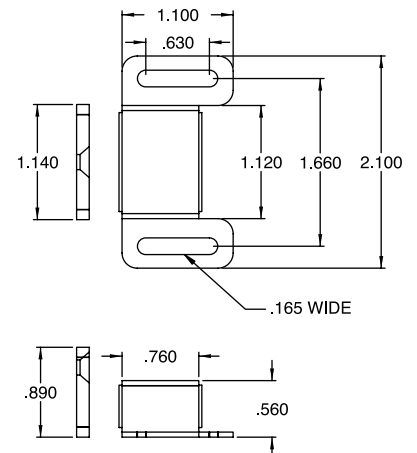

MAGNETIC DOOR CATCH BRACKET



ITEM #	DESCRIPTION
655471	Magnetic Door Catch Bracket

- Ideal for catching a framed-in extrusion door
- Use with Magnetic Door Catch
- 10 and 15 Series compatible
- Fasteners included – (2) 651080, (2) 651022, (2) 651163

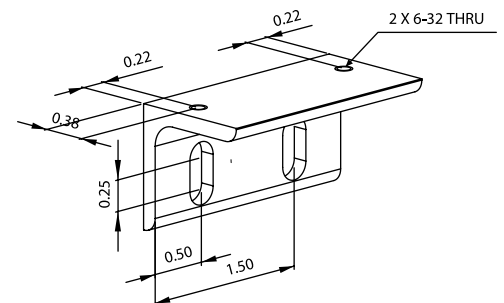

TOP MOUNT BIFOLD DOOR HANGER ASSEMBLY





ITEM #	DESCRIPTION
655057	10 S Top Mount Bifold Door Hanger 
655050	15 S Top Mount Bifold Door Hanger 

- Allows you to make a sliding or bifold door without using a bottom sliding rail.
- 10 and 15 Series compatible
- Fastens to extrusion end
- Rotates freely as door pivots
- Made from UHMW polyethylene

TOP MOUNT BIFOLD DOOR HANGER PROFILE



ITEM #	DESCRIPTION
657054	10 S Bifold Door Hanger Profile 
657087	15 S Bifold Door Hanger Profile 

- Allows you to make your own door hangers
- 10 and 15 Series compatible
- 120" stock length

TSLOTS Hardware

BLACK NYLATRON ROLLER WHEELS



ITEM #	DESCRIPTION
655222	10 S Roller Wheel 
655223	10 S To 15 S Roller Wheel
655224	15 S Economy Roller Wheel
655221	15 S Deluxe Roller Wheel

- Use for guided linear motion
- Mounts to extrusion end or in T-Slot
- Made of high strength black nylontrons
- Fasteners included
- 10 and 15 Series sizes

ITEM #	A	B	C	D	E	F	G	H	J	K	L	M	N	Q	P
655221	2	1.625	0.31	0.72	0.812	0.188	0.375	0.25	0.125	0.75	0.562	0.375	5/16-18	0.06	0.485
655224	2	1.625	0.31	0.72	0.812	0.188	0.375	0.25	0.125	0.75	0.562	0.375	5/16-18	0.06	0.485
655223	1.5	1.125	0.31	0.48	0.563	0.188	0.314	0.219	0.125	0.625	0.435	0.31	1/4-20	0.06	0.37
655222	1.5	1.125	0.24	0.48	0.563	0.188	0.314	0.219	0.125	0.625	0.435	0.31	1/4-20	0.06	0.37

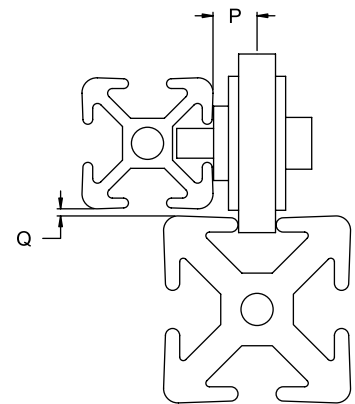
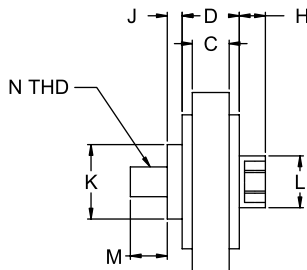
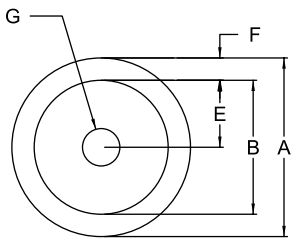

		MOUNTS TO								
		1 x 1	1 x 2	2 x 2	1.5 x 1.5	1.5 x 1.5L	1.5 x 3.0	1.5 x 3.0L	1.5 x 4.5	3 x 3
ROLLS IN	1 x 1	655222			655221 & 655224					
	1 x 2									
	2 x 2									
	1.5 x 1.5	655223								
	1.5 x 1.5L									
	1.5 x 3.0									
	1.5 x 3.0L									
	1.5 x 4.5									
	3 x 3									

ROLLER WHEEL BRACKETS AND ASSEMBLIES



- Ideal for framed doors
- Assembly part numbers include roller wheels
- Fasteners included for both assembly and bracket part numbers

ITEM #	DESCRIPTION
655472	1010 Roller Wheel Bracket (25S)
655473	1010 Roller Wheel Bracket w/ 655222 (25S)
655474	1020 Roller Wheel Bracket (25S)
655475	1020 Roller Wheel Bracket w/ 655222 (25S)
655476	15 S Roller Wheel Bracket
655477	15 S Roller Wheel Bracket w/ 655221
655478	15 S Roller Wheel Bracket w/ 655224
655479	15 S Roller Wheel Bracket
655480	1530 Roller Wheel Bracket w/ 655221
655481	1530 Roller Wheel Bracket w/ 655224

INCLUDED HARDWARE

QTY	SERIES	DESCRIPTION
2	10 S	1/4-20 x 3/8" LHSCS
2	10 S	1/4-20 Std T-Nut
2	15 S	5/16-18 x 5/8" LHSCS
2	15 S	5/16-18 Std T-Nut

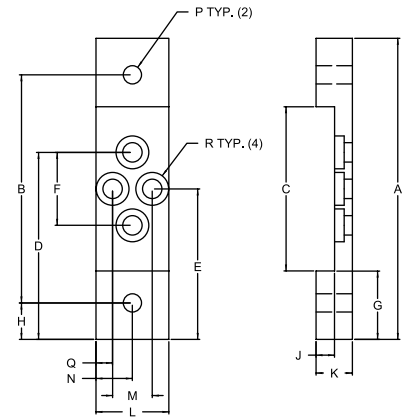

ITEM #	A	B	C	D	E	F	G	H	J	K	L	M	N	Q	P
655472	3.125	2.125	1.25	1.897	1.563	0.669	0.938	0.5	0.255	0.5	1	0.544	0.5	0.228	1/4-20
655474	4.125	3.125	2.25	2.562	2.063	1	0.938	0.5	0.255	0.5	1	0.544	0.5	0.228	1/4-20
655476	4.625	3.125	1.75	2.743	2.313	0.86	1.438	0.75	0.39	0.75	1.5	0.735	0.75	0.383	5/16-18
655479	6.125	4.625	3.25	3.813	3.063	1.5	1.438	0.75	0.39	0.75	1.5	0.735	0.75	0.383	5/16-18

ROLLER WHEEL BRACKETS AND ASSEMBLIES

655473

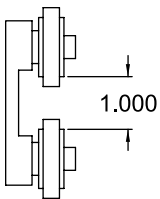

655475

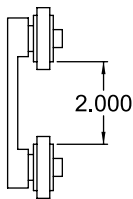

655477

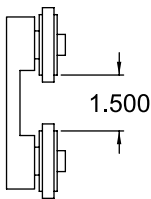

655478

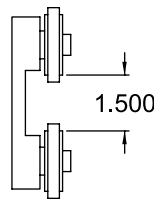

655480

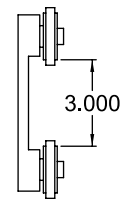

655481

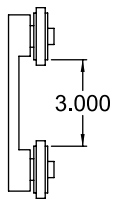





ASSEMBLY PART #	INDIVIDUAL PART NUMBER							
	655472	655474	655476	655479	655222	655223	655221	655224
655473	1				2			
655475		1			2			
655477			1				2	
655480				1			2	
655478			1					2
655481				1				2

TSLOTS Hardware

DOOR SLIDE TRACK



ITEM #	DESCRIPTION
655189	10 S Upper Door Slide Track 
655191	10 S Lower Door Slide Track 
655188	15 S Upper Door Slide Track 
655190	15 S Lower Door Slide Track 

- Snaps into T-Slot
- Deeper slot in upper track allows panel to be inserted after frame is assembled
- Radius bearing surface in lower track allows for easier sliding
- 10 and 15 Series sizes
- 145" stocked length

» See page 11:05 for miscellaneous cut charge.

To calculate panel height, subtract .5" from "N"

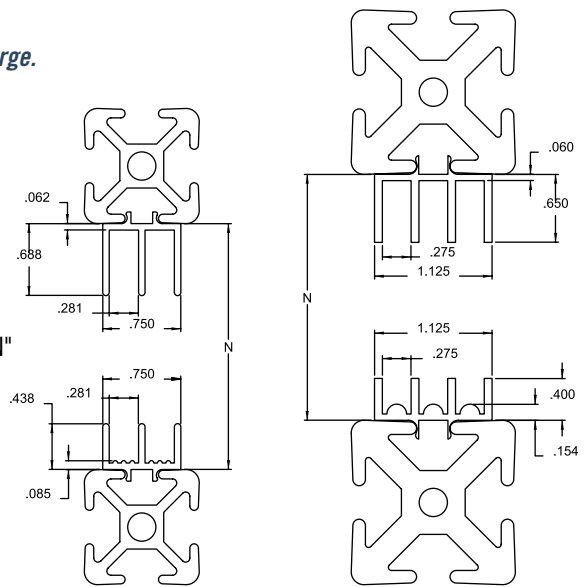

PANEL STIFFENER

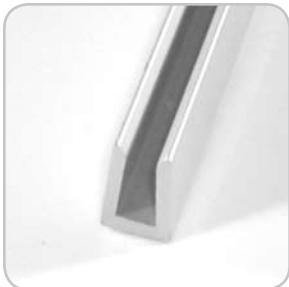

ITEM #	LENGTH	DESCRIPTION
655285	72"	Aluminum Panel Stiffener

- Increases the rigidity of 1/4" panels

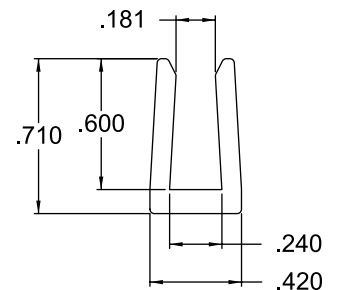

ECONOMY PLASTIC PANEL GASKET

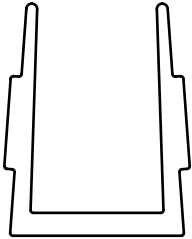

ITEM #	DESCRIPTION
655639	10 S Economy Plastic Panel Gasket 
655638	15 S Economy Plastic Panel Gasket 

DELUXE PLASTIC PANEL GASKET

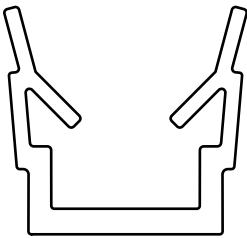

ITEM #	DESCRIPTION
655640	10 S Deluxe Plastic Panel Gasket 
655641	15 S Deluxe Plastic Panel Gasket 

- 10 S and 15 S Sizes
- The deluxe gasket can also be used as a T-Slot cover
- 15 S deluxe gasket will accommodate 3/16" and 1/4" panels
- 10 S deluxe gasket will accommodate 1/8" and 3/16" panels
- Made of HDPE - Black
- Stocked in 96" lengths

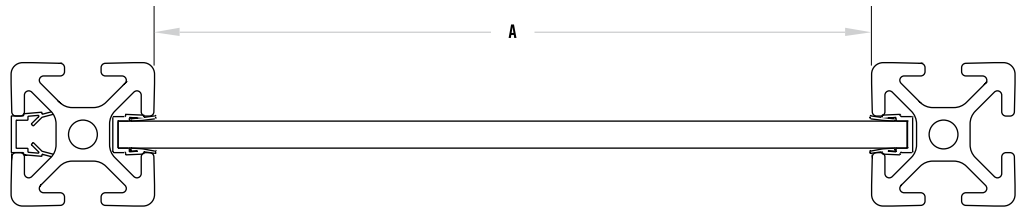

15 SERIES
TO CALCULATE PANEL HEIGHT,
ADD 75" TO "A"

10 SERIES
TO CALCULATE PANEL HEIGHT,
ADD 50" TO "A"

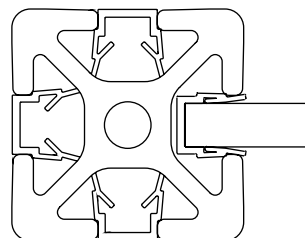

TSLOTS Hardware

PANEL MOUNT BLOCK

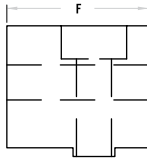
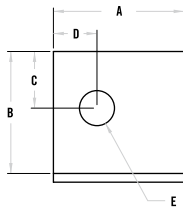

ITEM #	DESCRIPTION
655286	15 S Panel Mount Block
655288	10 S Panel Mount Block

655288 mounts 3/16" panels flush with 10 Series extrusions
 655286 mounts 1/4" panels flush with 15 Series extrusions

- Allows you to mount panel flush or offset with extrusion
- Simplifies adding or removing panels
- Drilling panel required
- Fasteners included

ITEM #	A	B	C	D	E	F
655288	0.75	0.7	0.325	0.25	1/4-20 TAP THRU	0.812
655286	1	0.88	0.44	0.39	5/16-18 TAP THRU	1.25

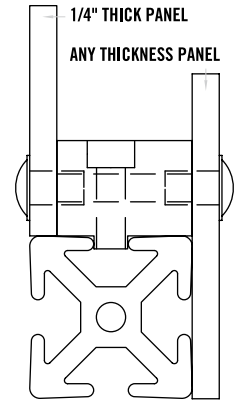

NYLON PANEL MOUNT BLOCK

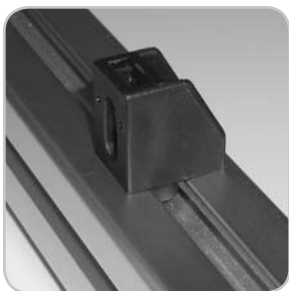

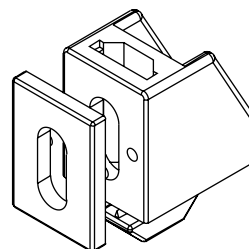
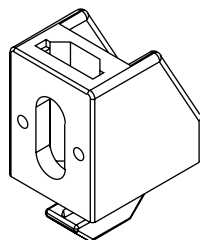

ITEM #	DESCRIPTION
655681	15 Series Nylon Panel Mount Block

- 15 Series Compatible
- Panel inserts from the top then twists 90° to lock into place.
- Includes 1/4-20 x 1" Mounting Screw
- Includes 2 Shims, One to mount a 1/4" panel flush to the extrusion and one to mount the 1/4" panel on the outside of the extrusion.
- Made of Black Nylon



PANEL MOUNT BRACKET



ITEM #	DESCRIPTION
655289	10 S Panel Mount Bracket 
655291	15 S Panel Mount Bracket 

RECOMMENDED FASTENERS FOR EXTRUSION

QTY	ITEM #
1	651166 (For Bracket Number #655289)
1	651128 (For Bracket Number #655291)

RECOMMENDED FASTENERS FOR 1/4" PANEL

QTY	ITEM #
1	651002 (For Bracket Number #655289)
1	651210 (For Bracket Number #655291)

- Lower cost alternative than Panel Mount Block
- Mounts 1/4" panel flush with 15 Series extrusion
- Slotted hole makes alignment easy
- Drilling panel required
- 10 and 15 Series sizes

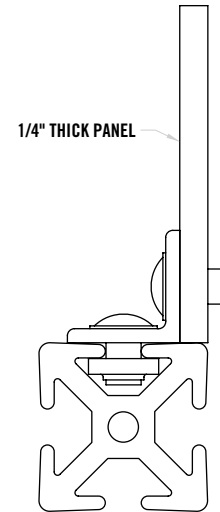

ITEM #	A	B	C	D	E	F	G	H	J
655289	1.00	1.00	0.25	0.5	0.5	1.00	0.257	0.255	0.125
655291	1.00	1.00	0.25	0.5	0.5	1.00	0.257	0.255	0.125

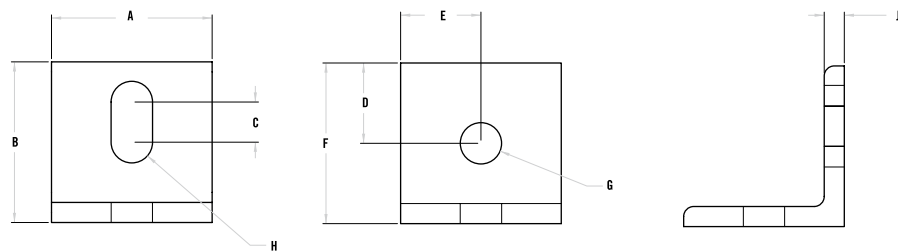

TSLOTS Hardware

PANEL RETAINER



ITEM #	DESCRIPTION
655329	10 S 1" Panel Retainer
655330	10 S 2" Panel Retainer
655295	15 S 1.5" Single Panel Retainer
655294	15 S 3" Single Panel Retainer
664039	40 S Single Panel Retainer

RECOMMENDED FASTENERS FOR EXTRUSION

QTY	ITEM #
1	651130 (For Bracket Number #655329)
1	651129 (For Bracket Number #655295)
2	651130 (For Bracket Number #655330)
2	651129 (For Bracket Number #655294)

RECOMMENDED FASTENERS FOR 1/4" PANEL

QTY	ITEM #
1	651169 (For Bracket Number #655329)
1	651135 (For Bracket Number #655295)
2	651169 (For Bracket Number #655330)
2	651135 (For Bracket Number #655294)

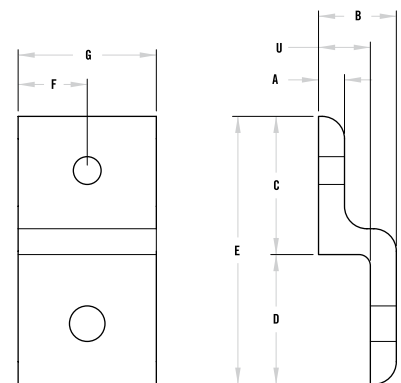
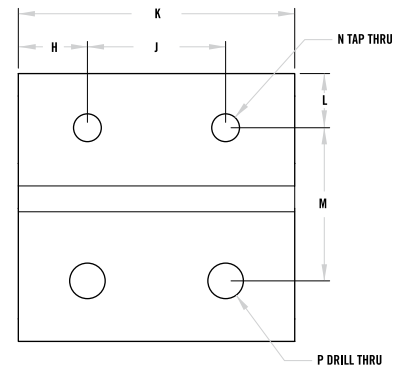

- Strongest way to retain panels
- Simplifies panel installation and removal
- Drilling panel required
- 10 and 15 Series sizes

	655329	655295	655330	655294
A	0.188	0.25	0.188	0.25
B	0.563	0.84	0.563	0.84
C	1	1.5	1	1.5
D	0.938	1.379	0.938	1.379
E	1.938	2.879	1.938	2.879
F	0.5	0.75		
G	1	1.5		
H			0.5	0.75
J			1	1.5
K			2	3.00
L	0.392	0.594	0.392	0.594
M	1.108	1.656	1.108	1.656
N	1/4-20	5/16-18	1/4-20	5/16-18
P	0.257	0.328	0.257	0.328
U	0.375	0.59	0.375	0.59



DOUBLE PANEL RETAINER



ITEM #	DESCRIPTION
655343	1" Double Panel Retainer 
655344	2" Double Panel Retainer 
655345	1.5" Double Panel Retainer
655346	3" Double Panel Retainer

RECOMMENDED FASTENERS FOR EXTRUSION

QTY	ITEM #
1	651130 (For 655343)
2	651130 (For 655344)
1	651129 (For 655345)
2	651129 (For 655346)

RECOMMENDED FASTENERS FOR 1/4" PANEL

QTY	ITEM #
2	651169 (For 655343)
4	651169 (For 655344)
2	651135 (For 655345)
4	651135 (For 655346)

- Strongest way to retain panels
- Simplifies panel installation and removal

	655343	655344	655345	655346
A	0.188	0.188	0.250	0.250
B	0.563	0.563	0.840	0.840
C	1.000	1.000	1.500	1.500
D	1.021	1.021	1.523	1.523
E	3.021	3.021	4.523	4.523
F	0.375	0.375	0.590	0.590
G	1.000	2.000	1.500	3.000
H	0.500	0.500	0.750	0.750
J		1.000		1.500
K	0.392	0.392	0.594	0.594
L	1.118	1.118	1.666	1.666
M	2.237	2.237	3.335	3.335
N	1/4-20	1/4-20	5/16-18	5/16-18
P	0.257	0.257	0.328	0.328

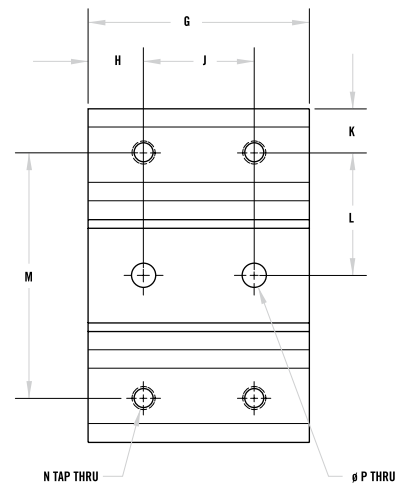
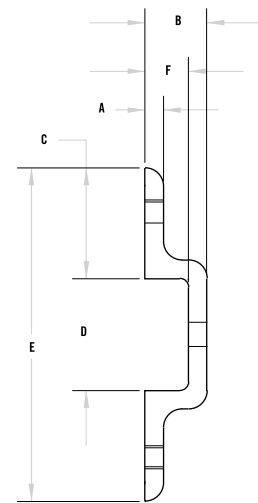

TSLOTS Hardware

MESH PANEL RETAINER



- Strongest way to retain wire mesh
- Prevents wire mesh from pushing out of T-Slot
- Simplifies installation and removal of wire mesh
- 10 and 15 Series sizes

ITEM #	DESCRIPTION
655323	1" Mesh Retainer ^(25S)
655293	1.5" Single Mesh Retainer
655326	2" Mesh Retainer ^(25S)
655292	3" Single Mesh Retainer
655324	1" Mesh Retainer w/ Backing Plate* ^(25S)
655297	1.5" Single Mesh Retainer w/ Backing Plate*
655327	2" Mesh Retainer w/ Backing Plate* ^(25S)
655296	3" Single Mesh Retainer w/ Double Backing Plate*
655325	1" Backing Plate ^(25S)
655299	Backing Plate For 1.5" Mesh Retainer
655328	2" Backing Plate ^(25S)
655298	3" Double Backing Plate
664066	40 S Single Mesh Retainer w/ Bacing Plate

**Fasteners for gauge wire included.*

RECOMMENDED FASTENERS FOR EXTRUSION

QTY	ITEM #
1	651130 (For Retainer Number #655324) & 655323
1	651129 (For Retainer Number #655297) & 655293
2	651130 (For Retainer Number #655327) & 655326
2	651129 (For Retainer Number #655296) & 655292

RECOMMENDED FASTENERS FOR GAUGE WIRE

QTY	ITEM #
1	651023 (For Retainer Number #655323)
1	651053 (For Retainer Number #655293)
2	651023 (For Retainer Number #655326)
2	651053 (For Retainer Number #655292)

	655324	655297	655327	655296
A	0.188	0.25	0.188	0.25
B	0.563	0.84	0.563	0.84
C	1	1.5	1	1.5
D	0.938	1.379	0.938	1.379
E	1.938	2.879	1.938	2.879
F	0.5	0.75		
G	1	1.5		
H			0.5	0.75
J			1	1.5
K			2	3
L	0.25	0.344	0.25	0.344
M	0.875	1.406	0.875	1.406
N	1/4-20	5/16-18	1/4-20	5/16-18
P	0.375	0.5	0.375	0.5
S	1	1.5	1	1.5
T	0.255	0.328	0.255	0.328
U	0.375	0.59	0.375	0.59
V	0.5	0.75	0.5	0.75

MESH RETAINER DETAIL

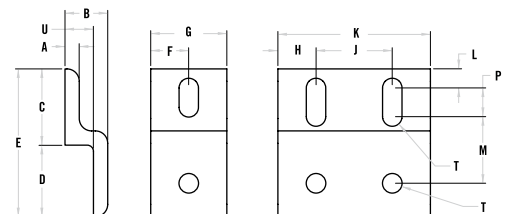

BACKING PLATE DETAIL

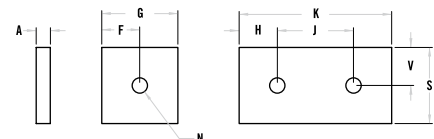

^(25S) 25 Series Compatible

^(40S) 40 Series Compatible

DOUBLE MESH PANEL RETAINER



- Prevents panels from pushing out
- Simplifies installation and removal

ITEM #	DESCRIPTION
655351	1" Double Mesh Retainer (25S)
655353	2" Double Mesh Retainer (25S)
655347	1.5" Double Mesh Retainer
655349	3" Double Mesh Retainer
655352	1" Double Mesh Retainer with Backing Plates * (25S)
655354	2" Double Mesh Retainer with Double Backing Plates * (25S)
655348	1.5" Double Mesh Retainer with Backing Plates *
655350	3" Double Mesh Retainer with Double Backing Plates *
655325	1" Backing Plate (25S)
655328	2" Double Backing Plate (25S)
655299	1.5" Backing Plate
655298	3" Double Backing Plate

**Fasteners for gauge wire included.*

RECOMMENDED FASTENERS FOR EXTRUSION

QTY	ITEM #
1	651130 (For 655351 & 655352)
2	651130 (For 655353 & 655354)
1	651129 (For 655347 & 655348)
2	651129 (For 655349 & 655350)

RECOMMENDED FASTENERS FOR GAUGE WIRE

QTY	ITEM #
2	651169 (For 655351)
4	651169 (For 655353)
2	651135 (For 655347)
4	651135 (For 655349)

	655351	655353	655347	655349
A	0.188	0.188	0.250	0.250
B	0.563	0.563	0.840	0.840
C	1.000	1.000	1.500	1.500
D	1.021	1.021	1.523	1.523
E	3.021	3.021	4.523	4.523
F	0.375	0.375	0.590	0.590
G	1.000	2.000	1.500	3.000
H	0.500	0.500	0.750	0.750
J		1.000		1.500
K	0.250	0.250	0.344	0.344
L	0.375	0.375	0.500	0.500
M	1.230	1.230	1.916	1.916
N	1/4-20	1/4-20	5/16-18	5/16-18
P	0.257	0.257	0.328	0.328
T	0.128	0.128	0.164	0.164

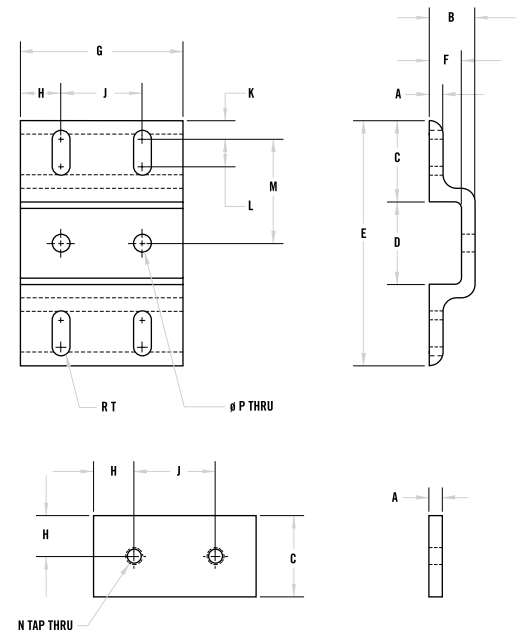

TSLOTS Hardware

PLASTIC PANELS 25S 40S



» See page 11:10 for machining services.

» See page 06:22 for area calculation matrix.

ITEM #	DESCRIPTION	THICKNESS	SHEET SIZE
655424	1/4" Clear Acrylic	0.236	4' x 8'
655425	3/16" Clear Acrylic	0.177	4' x 8'
655426	1/4" White Acrylic	0.236	4' x 8'
655427	3/16" White Acrylic	0.177	4' x 8'
655428	1/4" Black Acrylic	0.236	4' x 8'
655429	3/16" Black Acrylic	0.177	4' x 8'
655430	1/4" Bronze Acrylic	0.236	4' x 8'
655431	3/16" Bronze Acrylic	0.177	4' x 8'
655432	1/4" Clear Polycarbonate	0.236	4' x 8'
655433	3/16" Clear Polycarbonate	0.177	4' x 8'
655434	1/4" Bronze Polycarbonate	0.236	4' x 8'
655435	3/16" Bronze Polycarbonate	0.177	4' x 8'
655448	1/4" Gray Polycarbonate	0.236	4' x 8'
655449	3/16" Gray Polycarbonate	0.177	4' x 8'
655690	1/4" Black HOPE	0.236	4' x 8'
655691	1/4" Blue HOPE	0.236	4' x 8'
655695	1/4" Red HOPE	0.236	4' x 8'
655436	1/4" Black Haircell ABS	0.236	4' x 8'
655437	3/16" Black Haircell ABS	0.177	4' x 8'
655438	6mm White Expanded PVC	6mm	4' x 8'
655439	3mm White Expanded PVC	3mm	4' x 8'
655440	6mm Black Expanded PVC	6mm	4' x 8'
655441	3mm Black Expanded PVC	3mm	4' x 8'
655442	6mm Red Expanded PVC	6mm	4' x 8'
655443	3mm Red Expanded PVC	3mm	4' x 8'
655444	6mm Blue Expanded PVC	6mm	4' x 8'
655445	3mm Blue Expanded PVC	3mm	4' x 8'
655446	6mm Gray Expanded PVC	6mm	4' x 8'
655447	3mm Gray Expanded PVC	3mm	4' x 8'
655450	6mm Yellow Expanded PVC	6mm	4' x 8'
655451	3mm Yellow Expanded PVC	3mm	4' x 8'

- Use for guarding, enclosures, shelving, cabinets, etc.
- Machining Service – Panel Cut to Size 660062 & 660063
- Panels are ordered by the sq. ft.
- All panels can be used in 10, 15, 25 and 40 Series slots

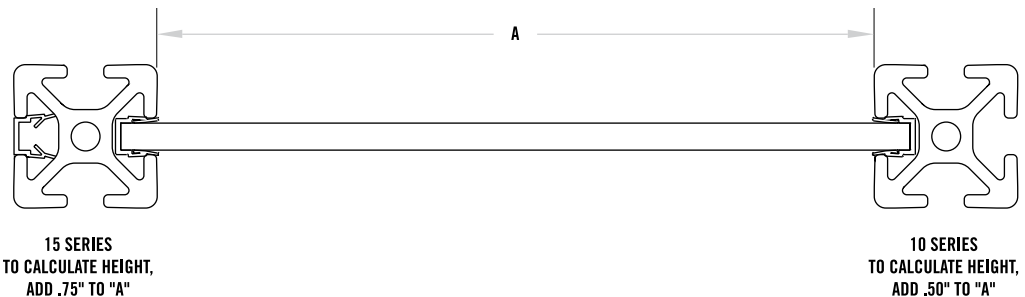

ALUCOBOND® PANELS









ITEM #	DESCRIPTION
655457	Alucobond 4mm Panel - Platinum  

- Silver painted .020" thick aluminum sheets separated by a thermoplastic core
- Lower cost alternative than a 1/4" thick aluminum panel
- Machining Service - Panel Cut to Size 660062 & 660063
- Stock panel size 48" x 120"

» See page 11:10 for cut to size services.
 » See page 06:22 for area calculation matrix.

ALUMALITE® PANELS









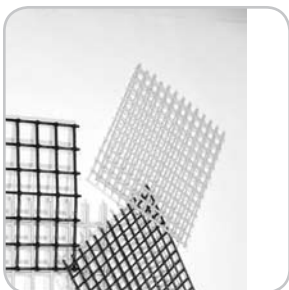

ITEM #	DESCRIPTION	SIZE
655452	6mm Alupalite Panel - Blue  	4' x 8'
655453	6mm Alupalite Panel - Red  	4' x 8'
655454	6mm Alupalite Panel - Silver  	4' x 8'
655455	6mm Alupalite Panel - Yellow  	4' x 8'

- Super lightweight
- Ideal for low impact enclosures
- Stock panel size 48" x 96"

» See page 11:10 for cut to size services.
 » See page 06:22 for area calculation matrix.

PVC COATED WIRE MESH



ITEM #	DESCRIPTION	WIRE GAUGE	THICKNESS
655318	1/2" x 1/2" Black PVC Coated Wire Mesh  	16	.14"
655319	1/2" x 1/2" Yellow PVC Coated Wire Mesh  	16	.14"
655316	1" x 1" Black PVC Coated Wire Mesh  	12	.21"
655317	1" x 1" Yellow PVC Coated Wire Mesh  	12	.21"

- Stocked in 4' x 8' sheets
- Cutting available - see page 11:10
- Use calculation matrix on page 06:22 to measure area
- Machining service - panel cut to size 660060 & 660061

TSLOTS Hardware

AREA CALCULATION MATRIX

HOW TO USE THE MATRIX

- Round both length and width dimensions up to the next 6" increment
- Find the length and width along the top and side of area calculation matrix
- Find the area in square feet at the intersection of the length and width matrix

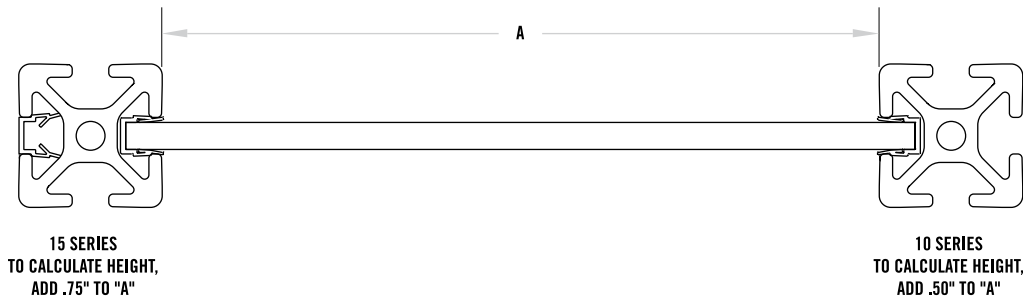

		WIDTH									
		6"	12"	18"	24"	30"	36"	42"	48"	54"	60"
LENGTH	6"	0.25	0.50	0.75	1.00	1.25	1.50	1.75	2.00	2.25	2.50
	12"	0.50	1.00	1.50	2.00	2.50	3.00	3.50	4.00	4.50	5.00
	18"	0.75	1.50	2.25	3.00	3.75	4.50	5.25	6.00	6.75	7.50
	24"	1.00	2.00	3.00	4.00	5.00	6.00	7.00	8.00	9.00	10.00
	30"	1.25	2.50	3.75	5.00	6.25	7.50	8.75	10.00	11.25	12.50
	36"	1.50	3.00	4.50	6.00	7.50	9.00	10.50	12.00	13.50	15.00
	42"	1.75	3.50	5.25	7.00	8.75	10.50	12.25	14.00	15.75	17.50
	48"	2.00	4.00	6.00	8.00	10.00	12.00	14.00	16.00	18.00	20.00
	54"	2.25	4.50	6.75	9.00	11.25	13.50	15.75	18.00	20.25	22.50
	60"	2.50	5.00	7.50	10.00	12.50	15.00	17.50	20.00	22.50	25.00
	66"	2.75	5.50	8.25	11.00	13.75	16.50	19.25	22.00	24.75	27.50
	72"	3.00	6.00	9.00	12.00	15.00	18.00	21.00	24.00	27.00	30.00
	78"	3.25	6.50	9.75	13.00	16.25	19.50	22.75	26.00	29.25	32.50
	84"	3.50	7.00	10.50	14.00	17.50	21.00	24.50	28.00	31.50	35.00
	90"	3.75	7.50	11.25	15.00	18.75	22.50	26.25	30.00	33.75	37.50
	96"	4.00	8.00	12.00	16.00	20.00	24.00	28.00	32.00	36.00	40.00
	102"	4.25	8.50	12.75	17.00	21.25	25.50	29.75	34.00	38.25	42.50
108"	4.50	9.00	13.50	18.00	22.50	27.00	31.50	36.00	40.50	45.00	

06:22

SLATWALL PANELS



ITEM #	DESCRIPTION
599900	12'6" Slatwall Panel
301901	12' Channel 3/4" x 1/2"

RECOMMENDED FASTENERS FOR 10 S TLOTS

QTY	ITEM #	DESCRIPTION
1	653273	10 to 15 S - 2 Hole Transition Strip
1	651130	1/4-20 x 1/2" FBHSCS & Economy T-Nut
1	651129	5/16-18 x 5/8" FBHSCS & Economy T-Nut

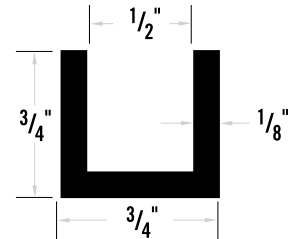

RECOMMENDED FASTENERS FOR 15 S TLOTS

QTY	ITEM #	DESCRIPTION
1	653141	15 S 2 Hole Joining Strip
2	651129	5/16-18 x 5/8" FBHSCS & Economy T-Nut

CALCULATION FORMULA FOR NUMBER OF PANELS NEEDED

$$\frac{(\text{Desired Panel Height} - 0.335)}{4.6}$$

- » For custom size panels, contact Futura Industries.
- » Round to the next full panel.

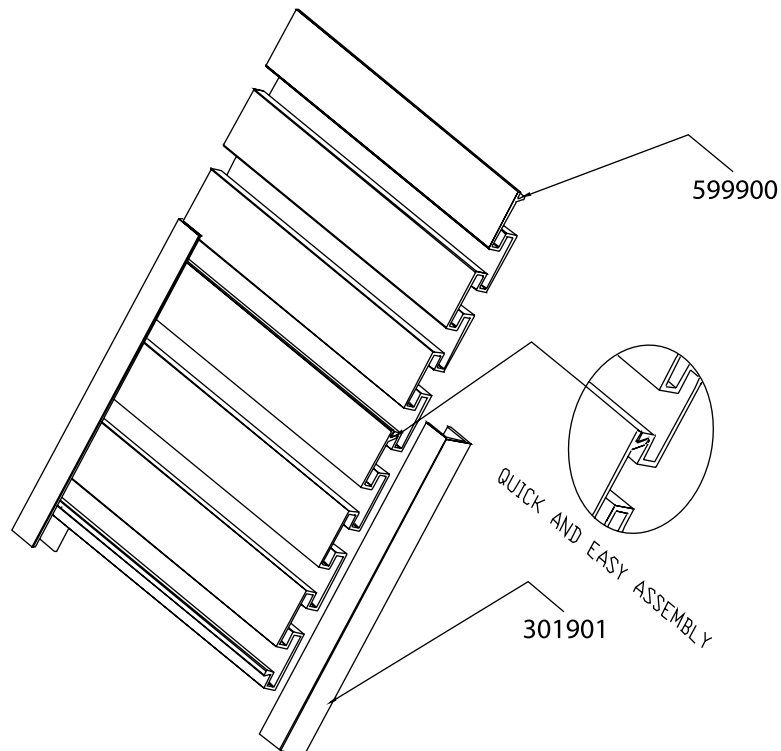
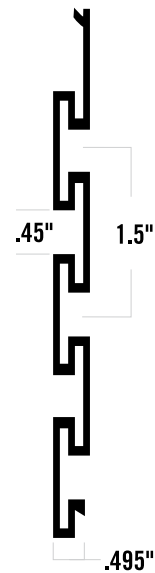

TSLOTS Hardware

45° SUPPORT

ITEM #	DESCRIPTION	QTY	INCLUDED HARDWARE
655371	1010 x 6" 45° Support	2	1/4-20 x 5/8" SHCS, Washer & Economy T-Nut
655375	1010 x 12" 45° Support	2	1/4-20 x 5/8" SHCS, Washer & Economy T-Nut
655380	1010 x 18" 45° Support	2	1/4-20 x 5/8" SHCS, Washer & Economy T-Nut
655372	1020 x 6" 45° Support	4	1/4-20 x 5/8" SHCS, Washer & Economy T-Nut
655373	1020 x 12" 45° Support	4	1/4-20 x 5/8" SHCS, Washer & Economy T-Nut
655374	1020 x 18" 45° Support	4	1/4-20 x 5/8" SHCS, Washer & Economy T-Nut
655355	1515 x 6" 45° Support	2	5/16-18 x 3/4" SHCS, Washer & Economy T-Nut
655359	1515 x 12" 45° Support	2	5/16-18 x 3/4" SHCS, Washer & Economy T-Nut
655363	1515 x 18" 45° Support	2	5/16-18 x 3/4" SHCS, Washer & Economy T-Nut
655365	1515 x 24" 45° Support	2	5/16-18 x 3/4" SHCS, Washer & Economy T-Nut
655367	1515-Lite x 12" 45° Support	2	5/16-18 x 3/4" SHCS, Washer & Economy T-Nut
655368	1515-Lite x 6" 45° Support	2	5/16-18 x 3/4" SHCS, Washer & Economy T-Nut
655369	1515-Lite x 18" 45° Support	2	5/16-18 x 3/4" SHCS, Washer & Economy T-Nut
655370	1515-Lite x 24" 45° Support	2	5/16-18 x 3/4" SHCS, Washer & Economy T-Nut
655357	1530 x 6" 45° Support	4	5/16-18 x 3/4" SHCS, Washer & Economy T-Nut
655361	1530 x 12" 45° Support	4	5/16-18 x 3/4" SHCS, Washer & Economy T-Nut
655364	1530 x 18" 45° Support	4	5/16-18 x 3/4" SHCS, Washer & Economy T-Nut
655366	1530 x 24" 45° Support	4	5/16-18 x 3/4" SHCS, Washer & Economy T-Nut
655381	1530-Lite x 6" 45° Support	4	5/16-18 x 3/4" SHCS, Washer & Economy T-Nut
655382	1530-Lite x 12" 45° Support	4	5/16-18 x 3/4" SHCS, Washer & Economy T-Nut
655383	1530-Lite x 18" 45° Support	4	5/16-18 x 3/4" SHCS, Washer & Economy T-Nut
655384	1530-Lite x 24" 45° Support	4	5/16-18 x 3/4" SHCS, Washer & Economy T-Nut
655356	1545 x 6" 45° Support	6	5/16-18 x 3/4" SHCS, Washer & Economy T-Nut
655358	1545 x 12" 45° Support	6	5/16-18 x 3/4" SHCS, Washer & Economy T-Nut
655360	1545 x 18" 45° Support	6	5/16-18 x 3/4" SHCS, Washer & Economy T-Nut
655362	1545 x 24" 45° Support	6	5/16-18 x 3/4" SHCS, Washer & Economy T-Nut

» All 45 degree supports have hardware already attached and come as an assembly.

- Create 45° supports without external joining plates or connectors.
- Custom lengths to your specifications.

15

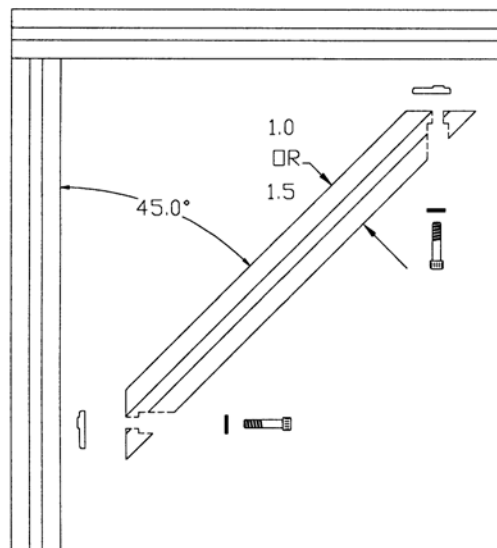
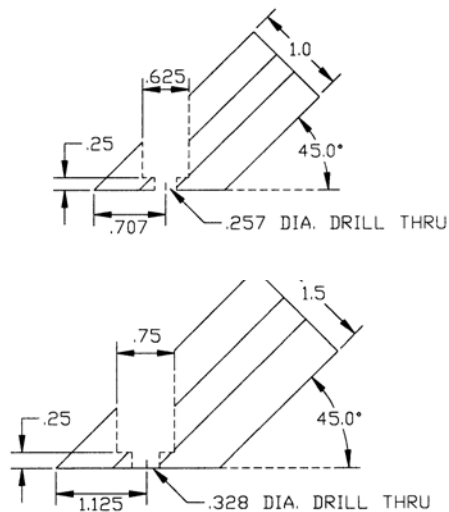

END CAPS



ITEM #	DESCRIPTION
655000	1" x 1" End Cap Black
655005	1" x 1" QR End Cap Black
655010	1" x 2" End Cap Black
655015	1" x 3" End Cap
655020	2" x 2" End Cap Black
655025	1.5" x 1.5" / 1.5" x 1.5" Lite End Cap Black
655030	1.5" x 1.5" QR End Cap Black
655035	1.5" x 3" / 1.5" x 3" Lite End Cap Black
655040	1.5" x 4.5" End Cap Black
655045	3" x 3" End Cap Black

- Allows you to cap off extrusion ends
- Push in fasteners included
- Can be mounted with 1/4-20 or 5/16-18 fasteners
- 10 and 15 Series sizes

» See page 04:09 for extra push in fasteners.

TSLOT COVERS

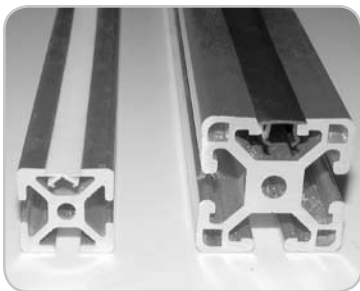

ITEM #	DESCRIPTION
655107	10 S Yellow T-Slot Cover 
655108	10 S Black T-Slot Cover 
655109	10 S Gray T-Slot Cover 
655104	15 S Yellow T-Slot Cover 
655105	15 S Black T-Slot Cover 
655106	15 S Gray T-Slot Cover 

- Covers T-Slot to keep dust and dirt out
- Covers wires and tubes in T-Slot
- Stocked in 72" lengths

TSLOTS Hardware

CART GUARD®

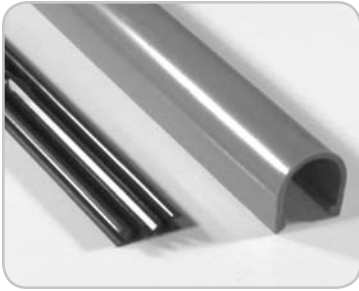

ITEM #	DESCRIPTION
655541	Cart Guard Mounting Base
655542	Cart Guard Cover – Black
655543	Cart Guard Cover – Gray
655544	Cart Guard Cover – Red
655545	Cart Guard Cover - Blue

RECOMMENDED FASTENERS

QTY	ITEM #	DESCRIPTION
1*	651229	1/4-20 x 3/8" SHCS & Economy T-Nut

*1 for every 4" of Cart Guard® Mounting Base

- 1" x 1" PVC Bumper
- Bolt on Mounting Base allows Cart Guard® Cover to snap to TSLOTS frame
- Stock length 144"

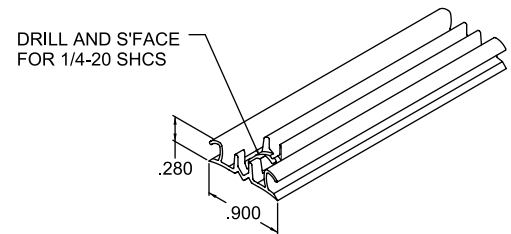
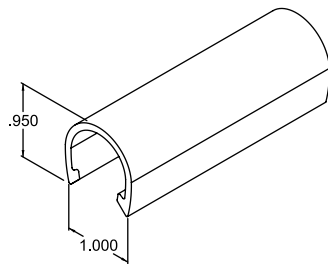

CART GUARD® CORNERS



COLOR	CORNER	SQUARE	ROUND
Black	655554	655550	655546
Gray	655555	655551	655547
Red	655556	655552	655548
Blue	655557	655553	655549

- End options: Square, Round, 90°
- Caps off exposed ends
- Mounting hardware included

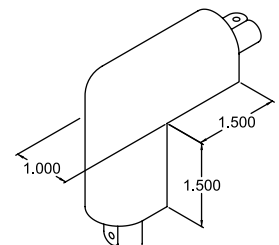
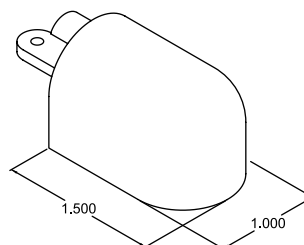
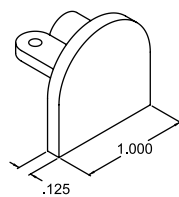

LAMINATED TABLE TOPS



ITEM #	DESCRIPTION
655509	30" x 48" x 1.25" Laminated Table Top – Gray
655510	30" x 48" x 1.25" Laminated Table Top – Almond
655511	30" x 60" x 1.25" Laminated Table Top – Gray
655512	30" x 60" x 1.25" Laminated Table Top – Almond
655513	30" x 72" x 1.25" Laminated Table Top – Gray
655514	30" x 72" x 1.25" Laminated Table Top – Almond
655515	36" x 72" x 1.25" Laminated Table Top – Gray
655516	36" x 72" x 1.25" Laminated Table Top – Almond

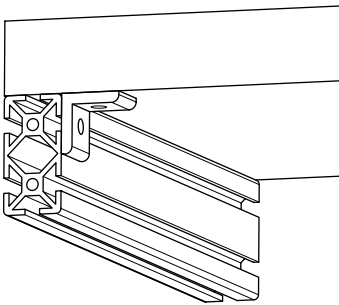

RECOMMENDED FASTENERS FOR 10 SERIES EXTRUSION

QTY	ITEM #	DESCRIPTION
1	655635	10 S Table Mount Assembly

RECOMMENDED FASTENERS FOR 15 SERIES EXTRUSION

QTY	ITEM #	DESCRIPTION
1	655636	15 S Table Mount Assembly

- 1.25" thick high-pressure laminate table top
- Comes in gray or almond

» Custom sizes and colors available upon request.

TOOL HANGERS



ITEM #	DESCRIPTION
655095	10 S Tool Hanger 
655096	15 S Tool Hanger 

- Ideal for hanging air tools, cable reels, heavy door panels or transporting cables
- Slides into the extrusion end and moves easily in the T-Slot
- 10 and 15 Series sizes
- 100 lb. Capacity

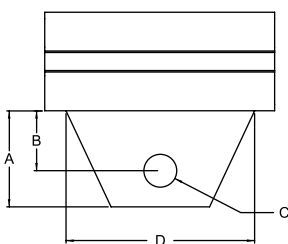

ITEM #	A	B	C	D
655095	1.10	.686	.328	2.00
655096	1.60	1.05	.500	3.00

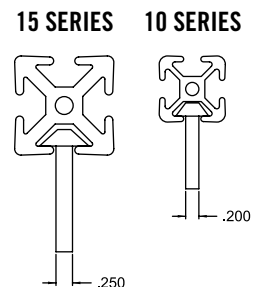

TSLOTS Hardware

TUBE AND WIRE CLAMP



ITEM #	DESCRIPTION
655331	1/8" Single Tube Clamp
655332	1/4" Single Tube Clamp
655333	3/8" Single Tube Clamp
655334	1/2" Single Tube Clamp
655335	3/4" Single Tube Clamp
655336	1" Single Tube Clamp
655337	1/8" Double Tube Clamp
655338	1/4" Double Tube Clamp
655339	3/8" Double Tube Clamp
655340	1/2" Double Tube Clamp
655341	3/4" Double Tube Clamp
655342	1" Double Tube Clamp

RECOMMENDED FASTENERS

SINGLE CLAMP	655331	655332	655333	655334	655335	655336
DOUBLE CLAMP	655337	655338	655339	655340	655341	655342
10 SERIES	651117	651117	651118	651120	651121	651121
15 SERIES	651117	651118	651119	651120	651121	651121

FASTENER SIZE

10 SERIES	15 SERIES	DESCRIPTION
1/4-20x3/4"	1/4-20x3/4"	1/8" Tube and Wire Clamp
1/4-20x3/4"	1/4-20x7/8"	1/4" Tube and Wire Clamp
1/4-20x7/8"	1/4-20x1"	3/8" Tube and Wire Clamp
1/4-20x1 1/4"	1/4-20x1 1/4"	1/2" Tube and Wire Clamp
1/4-20x1 1/2"	1/4-20x1 1/2"	3/4" Tube and Wire Clamp
1/4-20x1 1/2"	1/4-20x1 1/2"	1" Tube and Wire Clamp

- Organizes tubes and wires throughout your TSLOTS design
- Attaches easily to T-Slot
- Mounts 1/8" through 1" O.D. tubing and wires
- Oil, chemical and acid resistant
- Stackable design
- 10 and 15 Series compatible

10 SERIES PRESSURE MANIFOLD PLATES

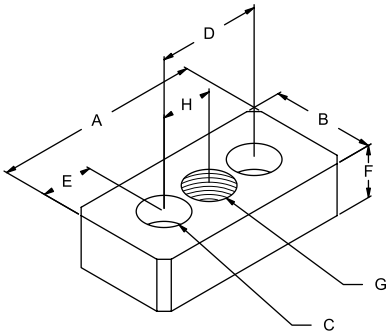

ITEM #	DESCRIPTION
655257	1" x 2" Blank Pressure Manifold Plate For Extrusion End
655300	1" x 2" 1/8" NPT Side Mount Pressure Manifold Plate
655141	1" x 2" 1/4" NPT End Mount Pressure Manifold Plate
655308	1" x 2" Blank Side Mount Pressure Manifold Plate
655303	1" x 3" Blank Pressure Manifold
655304	1" x 3" 1/4" NPT Blank Pressure Manifold
655258	2" x 2" Blank Pressure Manifold Plate For Extrusion End
655148	2" x 2" 3/8" NPT End Mount Pressure Manifold Plate

- Compatible with most fluids and gases
- Allows you to pressurize your machine
- 150 p.s.i. maximum pressure
- Item includes all fasteners and gaskets
- Contact us for custom manifolds

ITEM #	A	B	C	D	E	F	G	H
655257	2.00	1.00	DRILL THRU & C-BORE 1/4-20 SHCS	1.00	.500	.500	N/A	N/A
655300	2.00	1.00	DRILL THRU & C-BORE 1/4-20 SHCS	1.00	.500	.500	1/8"NPT	.500
655141	2.00	1.00	DRILL THRU & C-BORE 1/4-20 SHCS	1.00	.500	.500	1/4"NPT	.500
655303	3.00	1.00	DRILL THRU & C-BORE 1/4-20 SHCS	1.00	.500	.500	N/A	.500
655304	3.00	1.00	DRILL THRU & C-BORE 1/4-20 SHCS	1.00	.500	.500	1/4"NPT	.500
655308	2.00	1.00	DRILL THRU & C-BORE 1/4-20 SHCS	1.00	.500	.500	N/A	N/A
655258	2.00	2.00	DRILL THRU & C-BORE 1/4-20 SHCS	1.00	.500	.500	N/A	N/A
655300	2.00	2.00	DRILL THRU & C-BORE 1/4-20 SHCS	1.00	.500	.500	3/8"NPT	.500

TSLOTS Hardware

15 SERIES PRESSURE MANIFOLD PLATES

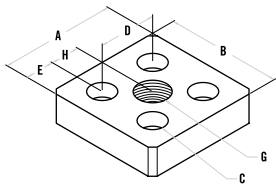
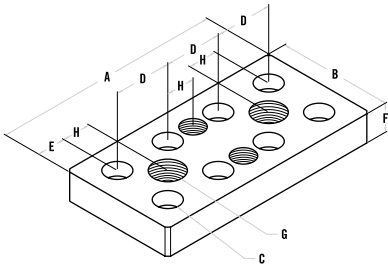

ITEM #	DESCRIPTION
655256	1.5" x 3" Blank Pressure Manifold Plate For Extrusion End
655307	1.5" x 3" Side Mount Blank Pressure Manifold Plate
655140	1.5" x 3" 3/8" NPT End Mount Pressure Manifold Plate
655302	1.5" x 3" 3/8" NPT Side Mount Pressure Manifold Plate
655301	1.5" x 3" 1/4" NPT Side Mount Pressure Manifold Plate
655259	3" x 3" Blank Pressure Manifold Plate For Extrusion End
655150	1.5" x 4.5" Blank End Mount Pressure Manifold Plate
655151	1.5" x 4.5" 3/8" NPT End Mount Pressure Manifold Plate

» Extrusion ends must be tapped a min of .75" for 10 Series and 1" deep for 15 Series.

ITEM #	A	B	C	D	E	F	G	H
655256	3.00	1.50	DRILL THRU & C-BORE 5/16-18 SHCS	1.50	.750	.750	N/A	N/A
655307	3.00	1.50	DRILL THRU & C-BORE 5/16-18 SHCS	1.50	.750	.750	N/A	N/A
655140	3.00	1.50	DRILL THRU & C-BORE 5/16-18 SHCS	1.50	.750	.750	3/8"NPT	.750
655302	3.00	1.50	DRILL THRU & C-BORE 5/16-18 SHCS	1.50	.750	.750	3/8"NPT	.750
655301	3.00	1.50	DRILL THRU & C-BORE 5/16-18 SHCS	1.50	.750	.750	1/4"NPT	.750
655259	3.00	1.50	DRILL THRU & C-BORE 5/16-18 SHCS	1.50	.750	.750	1/2"NPT	.750
655150	4.50	1.50	DRILL THRU & C-BORE 5/16-18 SHCS	1.50	.750	.750	N/A	N/A
655151	4.50	1.50	DRILL THRU & C-BORE 5/16-18 SHCS	1.50	.750	.750	3/8"NPT	N/A

REPLACEMENT GASKETS AND O-RINGS

	ITEM #	SIZE	MATERIAL
GASKETS	655142	1" x 2"	CR-20*
	655144	2" x 2"	CR-20*
	655143	1.5" x 3"	CR-20*
	655125	1.5" x 4.5"	CR-20*
	655145	3" x 3"	CR-20*
O-RINGS	655147	1" x 2"	RUBBER
	655146	1.5" x 3"	RUBBER

*CR-20 is a cork and synthetic rubber material manufactured by Global Technology Systems

TSLOTS Hardware

FURNITURE STYLE CASTERS



ITEM #	DESCRIPTION
655225	3" Furniture Style Caster w/o Brake  
655226	3" Furniture Style Caster w/ Brake  
655227	4" Furniture Style Caster w/o Brake  
655228	4" Furniture Style Caster w/ Brake  
655229	5" Furniture Style Caster w/o Brake  
655230	5" Furniture Style Caster w/ Brake  

- Brake kits are optional on Furniture Style Casters
- 165 lb. to 265 lb. Capacity
- 10 and 15 Series compatible

ITEM NUMBER	655225	655226	655227	655228	655229	655230
DIAMETER	3"	3"	4"	4"	5"	5"
CAPACITY	165	165	225	225	265	265
A	2.85	2.85	3.93	3.93	4.92	4.92
B	3/8-16	3/8-16	3/8-16	3/8-16	1/2-13	1/2-13
C	4.40	4.40	5.82	5.82	6.73	6.73
D	1.00	1.00	1.00	1.00	1.00	1.00
E	0.944	0.944	1.37	1.37	1.37	1.37
F	3.66	3.66	4.88	4.88	5.75	5.75
LOAD HEIGHT	3.15	3.15	4.33	4.33	5.24	5.24
WHEEL COLOR	Black	Black	Black	Black	Black	Black
LBS	.570	.570	.827	.827	1.312	1.312
BRAKE	No	Yes	No	Yes	No	Yes
MOUNTING PLATE	SEE PAGES 06:43 & 06:44					
COMPATIBILITY	10 & 15 SERIES					

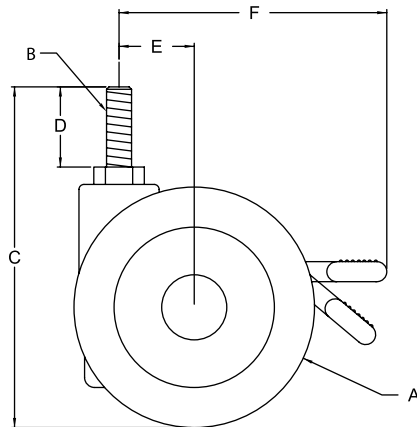

TSLOTS Hardware

TRIANGULAR TOP PLATE CASTERS



ITEM #	DESCRIPTION
655254	4" Triangular Top Plate Caster w/ Brake  
655255	5" Triangular Top Plate Caster w/ Brake  

- Swivel and Rigid casters available
- Total Lock® brakes on all swivel casters – Press to lock – Press to unlock
- Mounts to TSLOTS with caster mount plates on page 06:41.
- Double ball hardened raceways
- Zerk fittings in wheel bearing
- 250 lb. capacity

ITEM NUMBER	655254	655255
DIAMETER	4"	5"
CAPACITY	250	275
LOAD HEIGHT	5.75	6.75
WHEEL COLOR	Green	Green
LBS	2.805	2.91

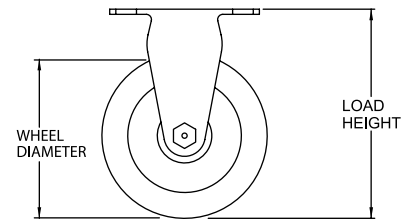
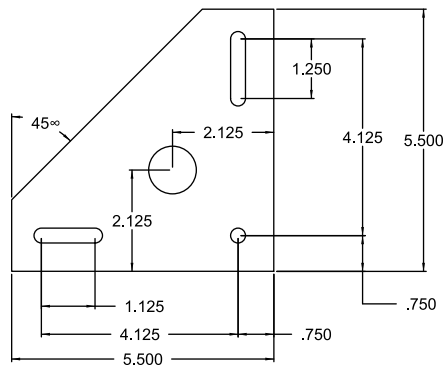

TSLOTS Hardware

FLANGE MOUNT CASTER BASE PLATE



ITEM #	DESCRIPTION
655279	10 S Flange Mount Caster Base Plate
655280	10 S Flange Mount Caster Base Plate
655281	15 S Flange Mount Caster Base Plate
655287	15 S Flange Mount Caster Base Plate

RECOMMENDED FASTENERS TO MOUNT TO EXTRUSION T-SLOT

BASE PLATE PART #	655279	655280	655281	655287
651205			4	4
651234	4	4		

RECOMMENDED FASTENERS TO MOUNT TO EXTRUSION END

BASE PLATE PART #	655279	655280	655281	655287
651059			4	4
651027	4	4		

- Mounts Flange Mount Caster and Deluxe Flange Mount Caster to extrusion
- Mount Base Plate to either extrusion end or slot
- 10 and 15 Series sizes

10 SERIES

ITEM #	655279	655280
A	2.50	2.50
B	.500	.500
C	3.75	3.75
D	2.94	2.94
E	.405	.405
F	.375	.375
G	1.75	1.75
H	1.375	1.375
J	1.00	1.00
L	.750	.750
LBS	.430	.430
M	5/16-18 TAP THRU	
N	DRILL THRU & C-BORE 1/4-20 SHCS	

15 SERIES

ITEM #	655281	655287
A	3.00	3.00
B	.750	.750
C	3.75	3.75
D	2.94	2.94
E	.405	.405
F	.625	.625
G	1.75	1.75
H	1.175	1.175
J	1.50	1.50
L	.750	.750
LBS	.755	.755
M	5/16-18 TAP THRU	
N	DRILL THRU & C-BORE 1/4-20 SHCS	

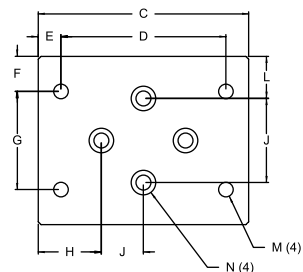
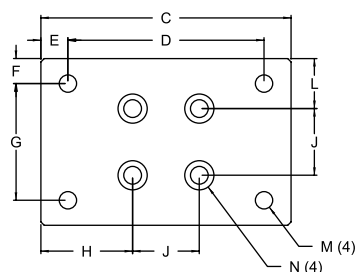

TSLOTS Hardware

HEAVY DUTY FLANGE MOUNT CASTERS



ITEM #	DESCRIPTION
655458	5" Heavy Duty Flange Mount Swivel Caster
655459	5" Heavy Duty Flange Mount Rigid Caster
655460	6" Heavy Duty Flange Mount Swivel Caster
655461	6" Heavy Duty Flange Mount Rigid Caster
655462	5" Heavy Duty Flange Mount Swivel Caster
655463	5" Heavy Duty Flange Mount Rigid Caster
655464	6" Heavy Duty Flange Mount Swivel Caster
655465	6" Heavy Duty Flange Mount Rigid Caster



- Swivel and Rigid casters available
- Comes in 5" and 6" diameters
- 425 lb. to 900 lb. capacity
- 15 Series compatible



RIGID CASTERS

ITEM NUMBER	655459	655461	655463	655465
DIAMETER	5"	6"	5"	6"
CAPACITY	425 lbs	475 lbs	900 lbs	900 lbs
LOAD HEIGHT	6.5"	7.5"	6.5"	7.5"
OIL RESISTANCE	Average	Average	Good	Good
WHEEL COLOR	Black	Black	Dark Red	Dark Red
LBS	4.50	5.50	4.50	5.00
MOUNTING PLATE	SEE PAGE 06:37	SEE PAGE 06:37	SEE PAGE 06:37	SEE PAGE 06:37
MOUNTING BOLTS	(4)651062	(4)651062	(4)651062	(4)651062



SWIVEL CASTERS

ITEM NUMBER	655458	655460	655462	655464
DIAMETER	5"	6"	5"	6"
CAPACITY	425 lbs	475 lbs	750 lbs	900 lbs
LOAD HEIGHT	6.5"	7.5"	6.5"	7.5"
OIL RESISTANCE	Average	Average	Good	Good
WHEEL COLOR	Black	Black	Dark Red	Dark Red
LBS	5.50	7.00	5.00	6.00
MOUNTING PLATE	SEE PAGE 06:37	SEE PAGE 06:37	SEE PAGE 06:37	SEE PAGE 06:37
MOUNTING BOLTS	(4)651062	(4)651062	(4)651062	(4)651062

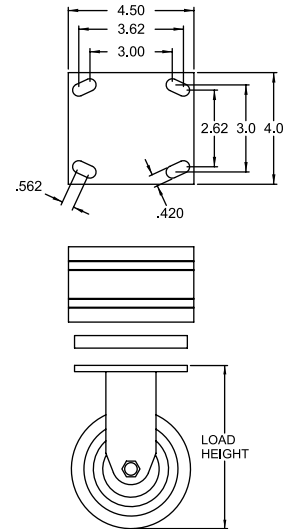

TSLOTS Hardware

ECONOMY ANTI-VIBRATION MOUNT



ITEM #	DESCRIPTION
655185	3/8-16 Economy Anti-Vibration Mount
655186	1/2-13 Economy Anti-Vibration Mount
655187	3/4-10 Economy Anti-Vibration Mount

- Reduces vibration transmission
- Level high precision or computerized machinery
- Gold irridite finish
- Black rubber vibration pad
- Available in three sizes

» Tap machining service required to load extrusion end. See page 11:06.

ITEM #	655185	655186	655187
A	3/8-16	1/2-13	3/4-10
B	1.25	1.875	3.00
C	3.50	3.75	4.125
D	2.00	2.00	2.00
E	1.50	1.75	2.125
F	.562	.625	1.062
LOAD CAPACITY	100 lbs	240 lbs	650 lbs

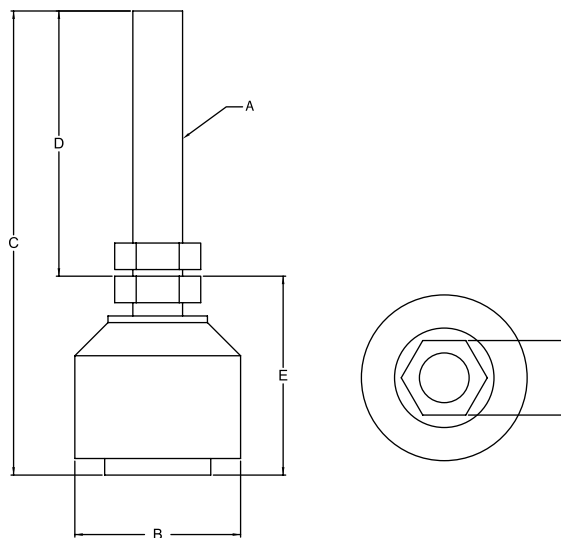

TSLOTS Hardware

ECONOMY LEVELING FEET



ITEM #	DESCRIPTION
655176	1/4-20 Economy Leveling Foot
655177	5/16-18 Economy Leveling Foot
655174	3/8-16 Economy Leveling Foot
655179	1/2-13 Economy Leveling Foot

- Threads directly into extrusion end or into 10 and 15 Series base plates
- Jam nut included
- 1050 lb. to 4700 lb. capacity
- 10 and 15 Series sizes

» Tap machining service required to load extrusion end. See page 11:06.

ITEM #	655176	655177	655174	655179
A	1/4-20	5/16-18	3/8-16	1/2-13
B	1.25	1.50	2.00	2.50
C	.094	.109	.141	.172
D	.563	.750	.875	1.063
LOAD CAPACITY	1050 lbs	1750 lbs	2550 lbs	7400 lbs

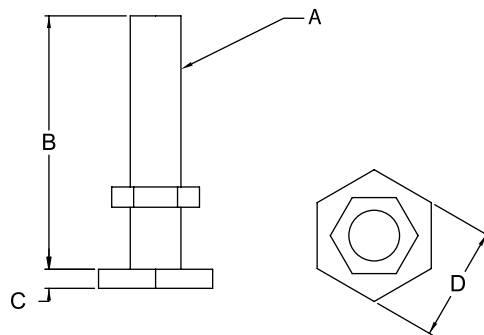

TSLOTS Hardware

15 SERIES BASE PLATES

ITEM #	DESCRIPTION	BOLT KIT TO T SLOT	MOUNT IN EXTRUSION END
655122	15 S 1.5" x 3" Base Plate w/ 3/8-16 Tap In Center	(2) 651205	(2) 651059
655128	15 S 1.5" x 3" Base Plate w/ 7/16-14 Tap In Center	(2) 651205	(2) 651059
655126	15 S 1.5" x 3" Base Plate w/ 1/2-13 Tap In Center	(2) 651205	(2) 651059
655264	15 S 1.5" x 3" Base Plate w/ 3/4-10 Tap In Center	(2) 651205	(2) 651059
655658	15 S 1.5" x 3" Base Plate Blank	(2) 651205	(2) 651059
655135	15 S 3" x 3" Base Plate w/ 7/16-14 Tap In Center	(4) 651205	(4) 651059
655130	15 S 3" x 3" Base Plate w/ 1/2-13 Tap In Center	(4) 651205	(4) 651059
655265	15 S 3" x 3" Base Plate w/ 3/4-10 Tap In Center	(4) 651205	(4) 651059
655659	15 S 3" x 3" Base Plate Blank	(4) 651205	(4) 651059
655136	15 S 3" x 3" Base Plate w/ 7/16-14 Corner Tap	(3) 651205	N/A
655131	15 S 3" x 3" Base Plate w/ 1/2-13 Corner Tap	(3) 651205	N/A
655266	15 S 3" x 3" Base Plate w/ 3/4-10 Corner Tap	(3) 651205	N/A
655665	15 S 3" x 3" Corner Tap Base Plate Blank	(3) 651205	N/A
655660	15 S 1.5" x 4.5" Base Plate Blank	(3) 651205	(3) 651059

- Mounts leveling feet and threaded stem casters to TSLOTS
- Bolts in extrusion end or in T-Slot
- See pages 06:39-06:42 for leveling feet
- See pages 06:31-06:32 for threaded stem casters

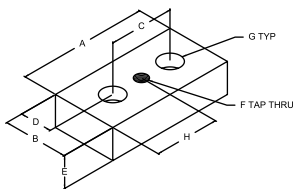

ITEM #	LBS	A	B	C	D	E	F	G	H
655122	.300	3.00	1.50	1.50	.750	.750	3/8-16	DRILL THRU & C-BORE FOR 5/16-18 SHCS	1.50
655128	.300	3.00	1.50	1.50	.750	.750	7/16-14	DRILL THRU & C-BORE FOR 5/16-18 SHCS	1.50
655126	.300	3.00	1.50	1.50	.750	.750	1/2-13	DRILL THRU & C-BORE FOR 5/16-18 SHCS	1.50
655264	.286	3.00	1.50	1.50	.750	.750	3/4-10	DRILL THRU & C-BORE FOR 5/16-18 SHCS	1.50
655658	.305	3.00	1.50	1.50	.750	.750	N/A	DRILL THRU & C-BORE FOR 5/16-18 SHCS	N/A

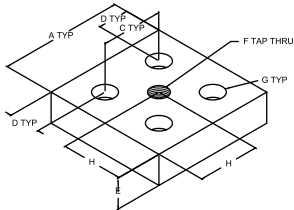

ITEM #	LBS	A	B	C	D	E	F	G	H
655135	.600	.300	N/A	1.5	.750	.750	7/16-14	DRILL THRU & C-BORE FOR 5/16-18 SHCS	1.50
655130	.600	.300	N/A	1.50	.750	.750	1/2-13	DRILL THRU & C-BORE FOR 5/16-18 SHCS	1.50
655265	.580	.300	N/A	1.50	.750	.750	3/4-10	DRILL THRU & C-BORE FOR 5/16-18 SHCS	1.50
655659	.610	.300	N/A	1.50	.750	.750	N/A	DRILL THRU & C-BORE FOR 5/16-18 SHCS	N/A

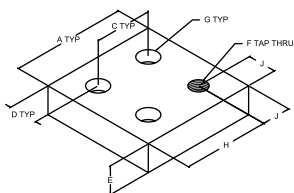

ITEM #	LBS	A	B	C	D	E	F	G	H	J
655136	.750	3.00	N/A	1.50	.750	.750	7/16-14	DRILL THRU & C-BORE FOR 5/16-18 SHCS	1.50	2.25
655131	.750	3.00	N/A	1.50	.750	.750	1/2-13	DRILL THRU & C-BORE FOR 5/16-18 SHCS	1.50	2.25
655266	.730	3.00	N/A	1.50	.750	.750	3/4-10	DRILL THRU & C-BORE FOR 5/16-18 SHCS	1.50	2.25
655665	.770	3.00	N/A	1.50	.750	.750	N/A	DRILL THRU & C-BORE FOR 5/16-18 SHCS	N/A	N/A

TSLOTS Hardware

BASE PLATES - FLOOR MOUNT 10 SERIES ECONOMY



655275

ITEM #	DESCRIPTION	BOLT KIT TO MOUNT TO T SLOT
655275	10 S 1" Economy Floor Mount Base Plate	(2) 651130
655277	10 S 2" Economy Floor Mount Base Plate	(4) 651130
655272	10 S 3" Economy Floor Mount Base Plate	(6) 651130

- Strong economy base plates
- Bolts directly in the T-Slot
- Allows vertical adjustments
- More economical than standard Floor Mount Base Plate



655277

ITEM #	655275	655277	655272
A	5.00	5.00	5.00
B	2.75	2.75	2.75
C	1.50	1.50	1.50
D	N/A	1.00	1.00
E	.250	.250	.250
F	2.00	2.00	2.00
G	.688	.688	.688
H	N/A	1.00	1.00
J	1.00	2.00	3.00
K	.257	.257	.257
L	.390	.390	.390
M	.875	.875	.875
N	.500	.500	.500
LBS	.175	.350	.525



655272

